

PRODUCT DATA Emshield™ DFR3 System

A SIKA COMPANY



EMSHIELD DFR displayed in typical substrate.

Product Description

Emshield DFR3 is a 3-hour UL-certified fire-rated and watertight expansion joint. It offers outstanding performance features and sizing specifications.

Emshield DFR3 features a traffic-grade silicone sealing surface adhered to a fire-retardant impregnated foam backing and an intumescent bellows on the bottom (fire) side.

The system is installed into epoxy adhesive field-applied onto the joint faces. A field-injected silicone sealant band seals the bellows to the substrate at the traffic surface. (NOTE: The DFR3 system was tested and passed UL 2079 without installation of intumescent sealant bands from the underside and these are therefore NOT needed). Joins between each stick are executed using a field-applied silicone sealant at the top of the joint and field-applied intumescent sealant on the adjoining faces below the silicone.

Traffic Durable, Watertight, 3-Hour Fire-Rated Expansion Joint

Emshield DFR3 is a watertight, fire-rated, traffic-durable, sound-attenuating primary seal for both retrofit and new structural expansion joints in horizontal-plane applications.

It eliminates the need for additional fire blankets, mineral wools, liquid sealants, cover plates, or other fire stopping materials.

For joints from 1/2-inch (12mm) up to 4-inches (100mm) where +25% and -25% (total 50%) of nominal material size joint movement is expected.

DFR3 (Deck, Fire-Rated 3-Hours) is part of a comprehensive line of breakthrough, multifunction, structural expansion joint materials manufactured by EMSEAL. Tested and certified by Underwriters Laboratories (UL), to the rigors of UL 2079, additional versions for walls and floors are now available — consult EMSEAL.

Fire-retardant-impregnated foam is factory pre-coated on the underside with an intumescent fireproofing material. The traffic surface receives a traffic-grade silicone coating. The resulting composite is then factory compressed to less than its nominal size for installation into structural or other openings.

Emshield DFR3 provides a watertight, clean handling, UV stable, nonstaining, low-temperature-flexible, high-temperature-stable, watertight, traffic durable, sound-suppressing, and fire-rated joint seal in a single installation process.

Features

Watertight – Emshield DFR3 is installed with the tension-less traffic-grade, fuel-resistant bellows facing the traffic ensuring that watertightness is achieved.

Fire-Rated – The fire-retardant-impregnated foam and intumescent bellows are installed facing the lower floor ensuring 3-hour fire protection in accordance with UL-2079.

Sound Attenuation – Emshield DFR3 minimizes sound transfer which often occurs at the expansion gap. Tested results of EMSHIELD foam products in a 1 1/2" gap in a STC 68/OITC 51 wall are an **STC value of 64** and an **OITC value of 52**.

Non-Invasive Anchoring – There are no hard metal-to-substrate connections with Emshield DFR3. This includes embedded pins, anchors, screws, bolts or tracks, trays or rails, flanges or coverplates. The system is locked to the joint faces by means of the 1) backpressure of the foam, 2) the epoxy adhesive, and 3) the injected sealant bands at the joint face.

Movement Capability – +25% and -25% (50% total) of nominal material size.

Versatility – The standard Emshield DFR3 top surface color is gray (other colors are optional). The standard underside color is "intumescent-red". This provides a visual inspection cue to ensure the presence of the fireproofing. At the designer's option, an additional silicone color coating can be applied to the under-side.

Joint-Size Variation – Uniform bellows appearance, and the ability to handle variations in joint size through size-switching, are among other system features.

Factory-Fabricated Termination and Transition — as in all EMSEAL expansion joint systems, continuity of seal through changes in plane and direction is an essential performance differentiator.

Emshield DFR3 is manufactured in straight-run sticks which can be joined in the field to EMSEAL's patent-pending factory-fabricated "Universal-90" Transitions and Terminations. (see page 4) These are factory-fabricated single-piece 90° units which are coated on both sides with both luminescent and silicone coating allowing them to be installed as an upturn termination or as a downturn termination. Each has a 12-inch long horizontal leg and a 6-inch vertical leg. Terminations end in a 45° sealed and mitered end. Transitions end in an uncoated 90° cut to be adhered to another transition piece as used in treads and risers, parapets, curbs and other short-rise applications.

In addition to guaranteeing watertightness, EMSEAL's "Universal-90 terminations and transitions" allow for much faster and secure installation by eliminating field cutting at angles.

Emshield DFR3 builds on EMSEAL's track record of over 30 years of innovation in sealing structural expansion joints with impregnated foam sealants.

Uses and Applications

For expansion joints in decks and floors where watertightness and/or a fire-rating and/or traffic durability are required. Applications examples are:

- Stadiums
- Parking decks
- Stair tower perimeters
- Deck-to-deck
- Arenas
- Floors
- Elevator tower perimeters
- Deck-to-wall

Can be used alone or under any other expansion joint cover, plate or filler where depth of substrate allows.

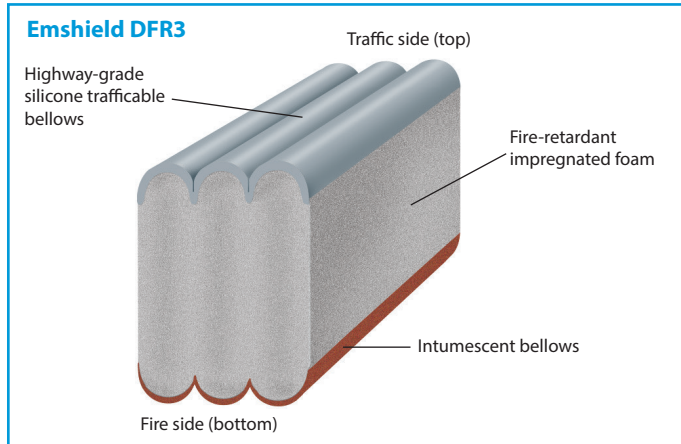

Performance

Capable of movements of +25%, -25% (50% total) of nominal material size.

Standard sizes from 1/2" (12mm) to 4" (100mm).

Depth of Seal for all sizes = 4" (100mm). Note: Typical thickness of concrete for a 3-hour rating = 4" (100mm).

Substrates must be solid, parallel and plumb.

Design/System/Construction/Assembly

This material has been tested to UL/ULC 2079 and is manufactured under UL's Follow-Up Service. The material is being supplied as a fire-rated component of a wall or floor assembly. It has been tested to UL 2079 in assemblies as depicted in EMSEAL's various listings in the UL Online Certifications Directory. Use of this material in assembly configurations other than depicted in the named UL listings will not encumber or lower the resistance of the deck or wall assembly but is done so at the designers' discretion and responsibility for designing substrates as part of a fire rated assembly that meet applicable standards for the project. Similarly, the published information in the UL Listings cannot always address every construction nuance encountered in the field. Authorities Having Jurisdiction should be consulted in all cases as to the particular requirements covering the installation and use of UL Listed or Classified products or materials. Authorities Having Jurisdiction should be consulted before construction to ensure that specific adjacent substrates and assemblies are detailed and constructed to meet local fire-rating requirements.

DFR3 System Sizing		
Product Code*	Nominal Material Size (Joint Size at Mean T°F)	Depth of Seal
DFR3-0050	1/2" (12mm)	4" (100mm)
DFR3-0065	5/8" (15mm)	4" (100mm)
DFR3-0075	3/4" (20mm)	4" (100mm)
DFR3-0100	1" (25mm)	4" (100mm)
DFR3-0125	1 1/4" (30mm)	4" (100mm)
DFR3-0150	1 1/2" (40mm)	4" (100mm)
DFR3-0175	1 3/4" (45mm)	4" (100mm)
DFR3-0200	2" (50mm)	4" (100mm)
DFR3-0225	2 1/4" (55mm)	4" (100mm)
DFR3-0250	2 1/2" (65mm)	4" (100mm)
DFR3-0275	2 3/4" (70mm)	4" (100mm)
DFR3-0300	3" (75mm)	4" (100mm)
DFR3-0325	3 1/4" (85mm)	4" (100mm)
DFR3-0350	3 1/2" (90mm)	4" (100mm)
DFR3-0375	3 3/4" (95mm)	4" (100mm)
DFR3-0400	4" (100mm)	4" (100mm)

Colors

Standard traffic surface color is Sikasil® WS-295 Deck Gray (consult EMSEAL for options). Standard underside color is "intumescent red" to facilitate visual inspection of presence of fire proofing. Additional color coating on bottom side is available as an option — consult EMSEAL.

Testing and Standards

Emshield DFR3 has been tested and certified under UL 2079. DFR3 is 3-hour fire rated.

Emshield DFR3 meets the requirements of ASTM E1966, ASTM E119 and ASTM E1399.

UL 2079, like ASTM E1966, was developed to encompass the fire testing of ASTM E119 and the movement cycling regime of ASTM E1399.

CAD & Guide Specs

Guide specifications and CAD details are available online at emseal.com or by contacting EMSEAL.

Warranty

Standard or project-specific warranties are available from EMSEAL on request. Each product can only perform its designed function if it, and the joint-gap into which it is installed, is sized to suit anticipated joint movements in consideration of the movement capability of the product and in consideration of the temperature at time of installation, and if it is installed in strict accordance with EMSEAL's installation instructions.

Availability & Price

Emshield DFR3 is available for shipment internationally. Prices are available from local representatives and/or directly from the manufacturer. The product range is continually being updated, and accordingly EMSEAL reserves the right to modify or withdraw any product without prior notice.

Emshield DFR

UL 2079 Testing and Certification

(This page shows the original testing of Emshield DFR.)

Manufacture

UL certification begins with certification of the manufacturing process. UL personnel observe the entire manufacturing process from impregnation to coating to packaging.

Installation

Next, an installation to include a joint between standard lengths, using the tools and procedures that will be used in the field is observed by UL. Specifically, 4-inch nominal DFR2 was installed into 4-inch thick concrete slabs (4-inches of concrete are required for the concrete itself to provide 2-hours of fire resistance). Once the epoxy-adhesive and liquid sealants used in the installation were cured, the slabs were ready for cycling.

Emshield DFR was tested both with just the intumescent bellows on the bottom side as well as with the intumescent bellows on the bottom side coated with a silicone bellows.

Joint Cycling

Before any fire testing can commence, the product must pass UL's cycling requirement through the extremes of the offered movement range (+25%, -25% from nominal). Joint movement under UL 2079 occurs at two levels. The first, 400 cycles @ 10 cycles/minute. This test is designed to simulate thermal and wind-sway cycling. The second, an additional 100 cycles @ 30 cycles per minute, is more rapid and is designed to simulate seismic movement. Emshield DFR2 passed cycling at both levels.

Fire Resistance

Within 96 hours of the cycling tests the fire testing must occur. The concrete slabs are installed over the test oven.

The joint gap is set at the maximum offered opening for the material size tested (4-inch nominal material at +25% movement claim = 5-inches).

Thermocouples are placed on the top side of the material. For the DFR, the thermocouples were placed directly on the material — in the middle of the product, at the substrate interface, and directly over the field-joint.

The oven is ignited and the temperature rises rapidly to near 1650°F (899°C) over 30 minutes. After two hours the internal temperature of the oven reaches 1850°F (1010°C).

The data from the thermocouples is monitored throughout the duration of the test. To pass, no single thermo couple can read in excess of 356°F (180°C) at any point during the duration of the test.

Final Results

After two hours, no single thermocouple on the Emshield DFR read in excess of 248°F (120°C).

The successful conclusion of the test earns the Emshield DFR the certification by UL of this product in sizes from 4-inches and smaller at depths of 4-inches and with a movement capability of +25% and -25% (total 50%) to be fire-rated for up to 2 hours.



UL System
FW-D-0078 FW-D-1090
FW-D-1053 FW-D-0075
ULC System
JF137 JF138

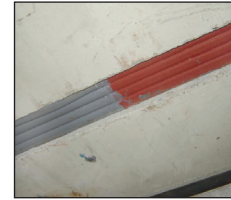

Bottom view (fire side) of intumescent-only and intumescent plus silicone bellows coating.



Joint gap at maximum expansion (+25% of nominal size.)

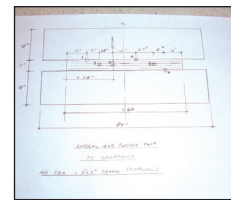

Thermocouples are placed in predetermined locations on top of the expansion joint to effectively measure heat transfer.



Testing oven below the Emshield DFR reaches a maximum temperature of 1850°F (1010°C).

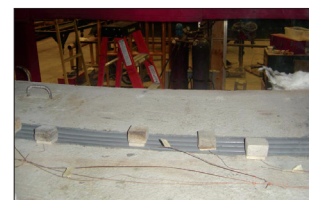

Thermocouples register no more than 248°F (120°C)

DFR3 In Deck Applications

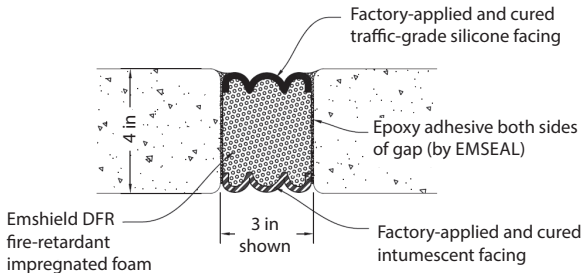

Deck to Deck

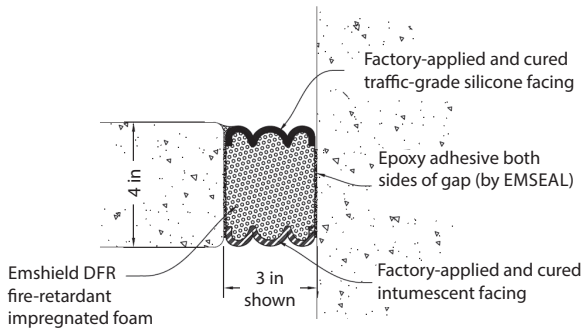

Deck to Wall

DFR3 Universal-90 Terminations and Transitions

US Patent: 9,200,437 Patent Pending

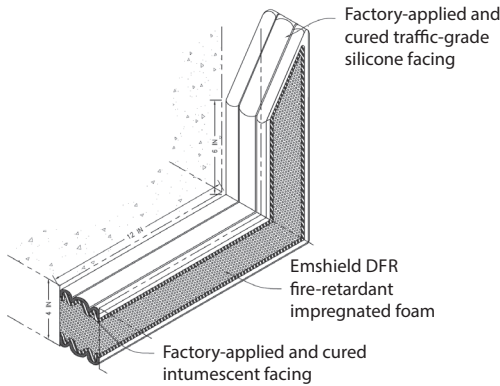

Upturn Termination to Vertical Rise

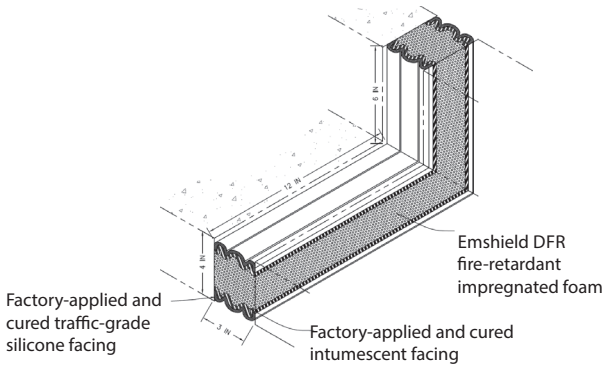

Horizontal to Vertical Upturn Transition

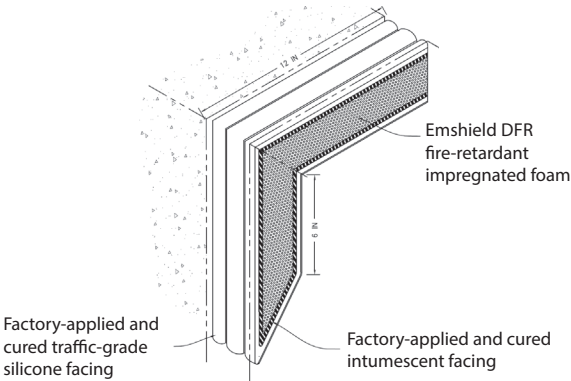

Downturn Termination to Vertical Overhang

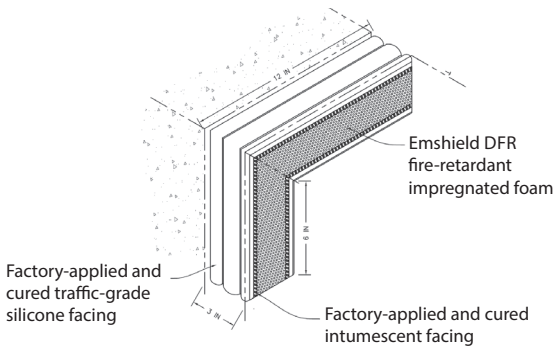

Horizontal to Vertical Downturn Transition